

## LÍNEA SBOX



### • PRESTACIONES / FEATURES

DURALUM:  
(TF 2003) nueva tecnología  
antihuellas de alta resistencia  
*new highly resistant fingerprint-proof  
technology*

PANEL DE MANDOS MECÁNICO  
*MECHANIC CONTROL PANEL*

Nº. VELOCIDADES: 3 (SBOX) 2 (TF 2003)  
*Nº. OF SPEEDS*

ILUMINACIÓN: 2 x 40W  
*LIGHTING*

DISTANCIAL MUEBLE 35 (TF 2003)  
*Distance to cabinet 35*

### • DATOS TÉCNICOS / TECHNICAL DATA

1 tangencial x 80W

CAUDAL: (salida libre / *free inlet delivery*)  
CAUDAL 600 m<sup>3</sup>/h  
Norma UNE I EN 61591:  
400 m<sup>3</sup>/h (15 Pa)

PRESIÓN MÁXIMA: 280 Pa  
*Maximum pressure*

NIVEL SONORO MÍNIMO: 44 dB (A)  
*Minimum noise level*

### • ACCESORIOS / ACCESSORIES

válvula antirretorno / *anti-return valve*  
filtros carbón activo / *activated charcoal filters*

## LÍNEA TF 2003 DurAlum®

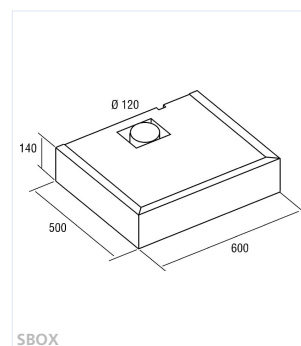

SBOX

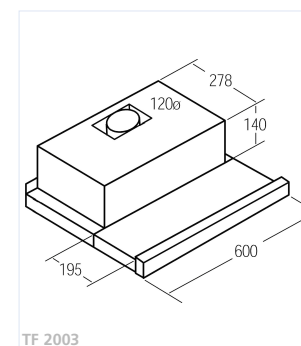

TF 2003



MÁS SILENCIOSO.  
MOTOR TANGENCIAL  
*MORE SILENT.  
TANGENTIAL MOTOR*

CÓDIGO / CODE	MODELO / MODEL	GAMA / RANGE	MEDIDAS / WIDTHS
02001300	SBOX	inox / <i>inox</i>	600 mm
02017000	TF 2003	blanca / <i>white</i>	600 mm
02017100	TF 2003	marrón/ <i>brown</i>	600 mm
02017301	TF 2003 DurAlum	inox antihuellas / <i>s.steel fingerprint-proof</i>	600 mm

cata